



Hospi-Gard® IsoClean® 800 & IsoClean® 400
HEPA Filtration Systems
INSTALLATION, OPERATION, AND MAINTENANCE MANUAL

ENVIRCO Technical Support: 800-884-0002

 **ENVIRCO**
Innovators in clean air technology

Table of Contents

Introduction.....	3
Installation	4
Operation.....	5
Maintenance & Service.....	7
Troubleshooting.....	11
Wiring Diagram.....	12
Specifications	14
Replacement Parts	15
Airflow Measurement & Testing	17
Air Change Rates	17
Limited Warranty	18
Contact Envirco	18

Installation, Operation, & Maintenance Manual

■ Introduction

Description

The Hospi-Gard® IsoClean® is a portable, self-contained high efficiency particulate air (HEPA) filtration system with an optional ultraviolet lamp that helps to disinfect the filter face. The IsoClean® is designed to easily and economically create a negative pressure isolation room that will meet OSHA and CDC TB guidelines. The IsoClean® can be used as a positive pressure clean air recirculating system in clinics, waiting rooms, hospital emergency rooms and other confined areas or as a partial or complete exhausting system to create a negative pressure isolation room for possible use with patients known or suspected of having TB, SARS, COVID-19, or other infectious diseases. The IsoClean® is available in two different sizes: the IsoClean® 400 and the IsoClean® 800. As a recirculating unit, the IsoClean®'s powerful motor/blower can deliver up to 370 CFM (628 m³/hr) for the IsoClean® 400 and up to 800 CFM (1360 m³/hr) for the IsoClean® 800 to provide a large number of room air changes per hour to minimize the spread of airborne diseases to patients and health care workers. As a negative pressure unit, the air passing through the HEPA filter is filtered of 99.99% of particles at 0.3 micron and may be exhausted directly to the exterior through a window, or through a wall, simply by connecting flexible ducting to the 6 in. (152 mm) collar located on the top of the IsoClean®.

Features

- **Low Cost Isolation Room**

The IsoClean® is an easy and economical solution for creating a negative pressure isolation room. Simply roll the IsoClean® into a standard room, connect flexible ducting to the 6 in. (152 mm) collar on the top of the unit for partial exhaust or to the optional 8 in. (204 mm) flanged collar for total exhaust, and vent the purified air to the exterior through a window or wall.

- **Flexible Applications**

The versatile IsoClean® can be used as a clean air recirculating unit, a negative pressure unit, or as a split system to create both negative pressure and clean air recirculation by simultaneously exhausting some of the air out while recirculating the remainder back into the room.

- **Small and Portable**

The IsoClean® can be rolled from one room to another and easily fits into areas with limited floor space.

- **Simple Maintenance**

Both HEPA filter and prefilter are easily accessible for replacement by authorized personnel.

- **Adjustable Airflow**

The IsoClean® provides effective air filtration for a wide variety of room sizes. The IsoClean® 400 utilizes a solid state speed control with airflows ranging from 70 to 370 CFM (118 to 628 m³/hr). The IsoClean® 800 utilizes a three position switch with airflows ranging from 560 to 800 CFM (951 to 1360 m³/hr).

- **Low-High Clean Air Circulation Pattern**

Room air, along with airborne contaminants, is drawn into the intake grill at the bottom while the purified air is discharged at a high velocity from the exhaust grill located at the top of the IsoClean® to generate a sweeping, low-to-high air circulation pattern with adequate "reach" to optimize the clean breathing zone for patient and staff.

- **Quiet Operation**

52 dBA on low, 56 dBA on medium, and 60 dBA on high speed measured 30 in. (762mm) from face of the unit.

Applications

Hospital

- Negative Pressure Rooms
- Emergency Rooms
- Waiting Rooms
- Sputum Induction
- Aerosol Pentamidine Treatment
- Intensive Care Units
- Bronchoscopy Rooms
- Renal Dialysis Rooms

Installation, Operation, & Maintenance Manual

Other

- Clinics
- Physician Offices
- Correctional Facilities
- Nursing Homes
- Homeless Shelters
- Addiction Recovery Center

Options

- IsoClean® with UV
- IsoClean® with ULPA Filter Upgrade
- Minihelic Pressure Gauge
- Keylock ON/OFF Switch
- 220 V, 50/60 Hz Unit Available
- 8 in. (203 mm) 100% Exhaust Collar Kit

■ **Installation**

Unpacking Instructions

1. The Hospi-Gard® IsoClean® is shipped in an open-framed crate. The module should be inspected for exterior shipping damage immediately upon arrival. If any damage is observed, a claims report should be completed and promptly filed with the responsible carrier.
2. Uncrate and remove all packing material. Examine the unit for internal damage. If damage is discovered inside the crating, file a claim with the responsible carrier immediately. The shipping components list and actual material received should be compared and any shortages reported to Envirco immediately.

Assembly

1. The Hospi-Gard® IsoClean® is shipped completely assembled from the factory and requires no assembly. Every unit is tested prior to shipment to verify airflow and that the unit is leak-free.
2. Place the unit in its final operating position.
3. Lock the wheel locks on the casters to keep the unit from accidental repositioning.

Initial Start-Up

NOTE: THE CDC REQUIRES THAT QUANTITATIVE LEAKAGE AND FILTER PERFORMANCE TESTS BE PERFORMED AT THE INITIAL INSTALLATION AND EVERY TIME THE FILTER IS CHANGED OR MOVED. TESTS SHOULD BE REPEATED EVERY SIX MONTHS OR THE APPROPRIATE TIMEFRAME THAT IS REQUIRED FOR THE APPLICATION. THE FACTORY TESTS SHOULD NOT BE SUBSTITUTED FOR THE INITIAL TEST.

CAUTION AND WARNINGS

READ AND SAVE THESE INSTRUCTIONS

WARNING: To reduce the risk of fire, electrical shock, or injury to persons, observe the following.

1. Installation work and electrical wiring must be done by a qualified person(s) in accordance with all applicable codes and standards, including fire-rated construction.
2. Service to this equipment should be performed by an authorized technician trained and experienced in performance evaluation and maintenance of clean air equipment.
3. Before servicing or cleaning unit, unplug the unit power cord from outlet to prevent power from being switched on accidentally.
4. This unit may have UV lamps. Eye damage may result from direct exposure to the light. Take UV radiation protective measures for personnel during service.
5. Use this unit only in the manner intended by the manufacturer.

Installation, Operation, & Maintenance Manual

■ Operation

Initial Start-Up

1. Connect the power cord to a standard 115-Volt, Single Phase, 60 Hertz, or 220-Volt, 50/60 Hertz, grounded power source. Verify that the circuit is sized to provide sufficient amperage as noted on the Hospi-Gard® IsoClean® data plate.
2. Locate the “ON/OFF” switch on the right side of the unit. The switch is a maintain contact rocker type.
3. Turn the Hospi-Gard® IsoClean® unit on by pressing downward on the raised portion of the rocker switch. A light whirring sound will be heard as the motor starts. Within 5 to 10 seconds, the module will start to provide clean air into the environment.

Speed Adjustment

Note: The Hospi-Gard® IsoClean® unit is set on high speed at the factory.

1. To change speeds, remove the exhaust grille by pulling down and lifting out.
2. Turn the 3-speed switch (or solid state speed control) to the desired setting on the IsoClean® 800 or 400.
3. Replace the exhaust grille when finished.

Filter Change Indicator

1. Locate the airflow indicator on the right side of the unit above the “ON/OFF” switch. On high speed, the light will turn on when there is insufficient pressure, indicating the need for a filter change. It is recommended to change prefilter. If the filter change indicator light is still illuminated, it is recommended to replace the HEPA filter. The airflow indicator should not be used as the only guide for when a filter change is necessary. The unit should be checked at each use to ensure recommended room air changes per hour are being met.
2. The filter change indicator light can be adjusted by adjusting the pressure switch which can be seen on the back panel of the IsoClean®. For setting the light, block the lower intake grill approximately 75% while the unit is on high speed. The pressure switch should be set to have the light flicker while covered 75%. Once the restriction is removed, the light should go off. If the intake grille is completely covered, the light should be solid on.
3. The air velocity generated by the unit may be checked using an airflow measurement device. The volume of air entering the lower intake grille should be approximately 560 CFM (951 m³/h) on low, 690 CFM (1172 m³/h) on medium, and 800 CFM (1359 m³/h) on high with a new filter for the IsoClean® 800. Air volume on the IsoClean® 400 should be approximately 70 CFM (118 m³/h) to 370 CFM (628 m³/h) depending on the position of the speed control with a new filter.

Recirculation Mode

1. The Hospi-Gard® IsoClean® unit is set at the factory on the 100% air recirculation mode.
2. The room air change rate of the unit will depend on both the Hospi-Gard IsoClean speed setting and the size of the room. See Air Change Rates on page 17 for representative room air changes per hour (ACH).
3. For maximum recirculation efficiency, the unit should be placed between the entry door and the patient’s bed or the activity area (see Figure 1 below). However, the unit will function effectively at other locations within the room.

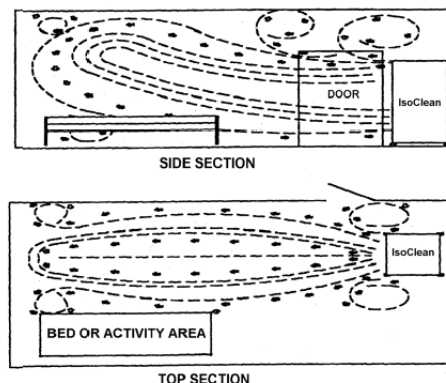

Figure 1: Recommended Hospi-Gard IsoClean Positioning within a Patient Room

Installation, Operation, & Maintenance Manual

Partial Exhaust/Recirculation Mode

Note: The IsoClean® units come with a removable Exhaust Cover Plate and a removable 6-inch (152mm) Duct Collar for attachment to exhaust ducting (not included) to create a negative pressure room. If the Exhaust Cover Plate is not removed, the IsoClean® units will operate in the 100% recirculation mode.

1. Remove the Exhaust Cover Plate located on top of the IsoClean® unit by taking off the four (4) screws and plastic caps used to secure the cover to the IsoClean® exhaust port.
2. Remove the 6-inch (152mm) duct collar underneath the top cover and flip the collar over.
3. Attach exhaust ducting (not included) onto the collar and fasten tightly with a round hose clamp (not included).
4. Mount the duct collar with ducting onto the IsoClean® exhaust port using the four (4) screws that originally held the cover plate. **Note:** Keep the top plate and plastic washers for re-assembly when needed.
5. The HEPA filtered exhaust air can now be vented to the outside or returned to the main HVAC system¹. If the unit is ducted to an exhaust duct rather than directly to the outside, it must be verified that the exhaust duct is capable of handling the exhaust air expelled by the unit.
6. The IsoClean® is designed to exhaust 100-300 CFM for the 800 and 25-150 CFM for the 400 at the 6-inch exhaust port. It is recommended that the unit be set on the high-speed setting when operating in this mode to achieve maximum exhaust and negative pressure. At this setting, the IsoClean® will exhaust approximately 300 CFM (510 m³/h) and recirculate 500 CFM (850 m³/h) for the 800 and exhaust approximately 150 CFM (254 m³/h) and recirculate 220 CFM (373 m³/h) for the 400.

Total Exhaust Mode (Negative Pressure)

CAUTION: To reduce risk of fire and to properly exhaust air, be sure to duct air outside - Do not vent exhaust air into spaces within walls or ceilings or into attics, crawl spaces, or garages.

CAUTION: For General Ventilating Use Only. Do Not Use to Exhaust Hazardous or Explosive Materials and Vapors.

Note: The cover plate must be securely attached to the top of the IsoClean® for the unit to run in the 100% exhaust mode.

An optional 8-inch (203mm) Exhaust Collar with Flange is available to convert the IsoClean® unit to the 100% exhaust mode.

1. Remove the front exhaust grille by pulling down and lifting out.
2. Place the optional 8-inch (203mm) exhaust collar over the opening where the grille was removed and attach with the screws included with the 8-inch collar.
3. Attach flexible exhaust duct (not included) over the 8-inch collar and fasten tightly with a round hose clamp (not included).
4. The HEPA filtered exhaust air can now be vented to the outside or returned to the main HVAC system¹. If the unit is ducted to an exhaust duct rather than directly to the outside, it must be verified that the exhaust duct is capable of handling the exhaust air expelled by the unit.

Negative Pressure

NOTE: CDC GUIDELINES RECOMMEND THAT ROOMS USED FOR NEGATIVE PRESSURE ISOLATION SHOULD BE SINGLE PATIENT ROOMS WITH NEGATIVE PRESSURE RELATIVE TO THE CORRIDOR OR OTHER AREAS CONNECTED TO THE ROOM. THE MINIMUM PRESSURE DIFFERENCE NECESSARY TO ACHIEVE AND MAINTAIN NEGATIVE PRESSURE THAT WILL RESULT IN AIRFLOW INTO THE ROOM IS 0.01 INCH W.G. (2.5PA) (A HIGHER PRESSURE IS PREFERRED). TO ACHIEVE THIS, THE EXHAUST FLOW SHOULD BE 10% OR 50 CFM (85 M³/H) GREATER THAN THE SUPPLY (WHICHEVER IS GREATER).

Achieving Negative Pressure

1. The IsoClean® unit is designed to exhaust 100-300 CFM (800 unit) or 25-150 CFM (400 unit) when the 6-inch (152.4mm) exhaust collar is used. It is recommended that the unit be set on the high-speed setting when operating in this mode to achieve maximum exhaust and negative pressure.
2. If an exhaust volume greater than 300 CFM (800 unit) or 150 CFM (400 unit) is required to create a negative pressure room, the optional 8-inch (203.2 mm) 100% exhaust collar should be used.
3. The attachment of ductwork to the exhaust port decreases the air volume exhausted through the port. The magnitude of the decrease varies depending on the length and type of duct as well as unit configuration.

¹ CDC recommends that air from negative pressure rooms be exhausted to the outside in accordance with federal, state, local or country regulations. The air should not be recirculated into the general ventilation. In certain cases in existing facilities, recirculation of air into the general ventilation system is unavoidable and, in such cases, CDC guidelines state that HEPA filters should be installed in the exhaust duct leading from the room to the general ventilation system.

Installation, Operation, & Maintenance Manual

NOTE: IT IS THE RESPONSIBILITY OF THE PURCHASER, AND NOT ENVIRCO, TO ENSURE THE ROOM IN WHICH THE UNIT IS USED IS IN COMPLIANCE WITH CDC GUIDELINES² FOR A NEGATIVE PRESSURE ISOLATION ROOM AND MONITORED TO ENSURE ITS CONTINUING PERFORMANCE.

Difficulty Achieving Negative Pressure

The equipment may not be able to achieve or maintain negative pressure in conformance with the CDC Guidelines² due to building ventilation of rooms or air leakage. The room should be inspected for air leakage through doors, windows, plumbing, and wall penetrations. Appropriate corrective action should be taken to seal leaks.

■ Maintenance & Service

Parts Identification

Hospi-Gard IsoClean 800

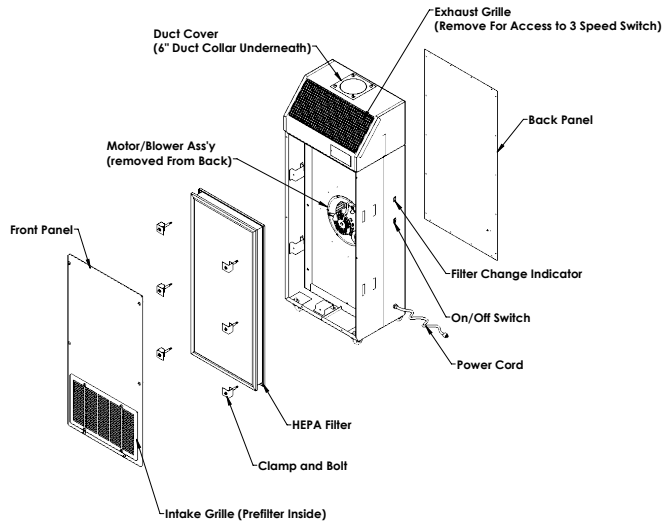

Hospi-Gard IsoClean 800 UV

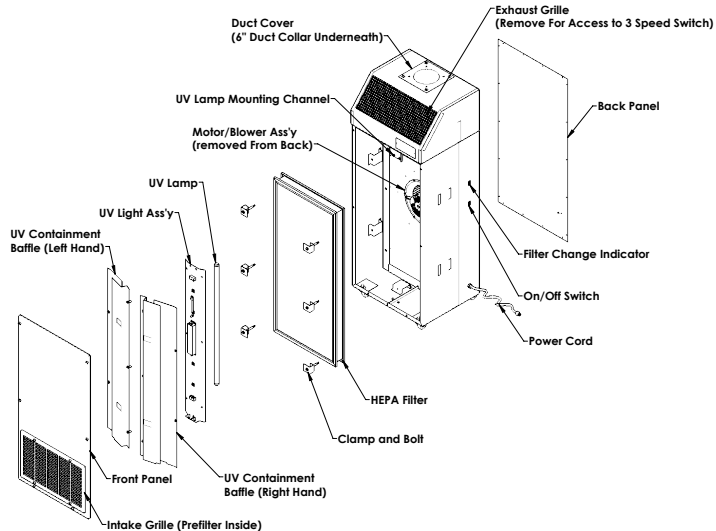

² CDC. Guidelines for Preventing the Transmission of Tuberculosis in Healthcare Facilities, 1994. MMWR, October 28, 1994; 43 (No. RR-13.)

Installation, Operation, & Maintenance Manual

Hospi-Gard IsoClean 400

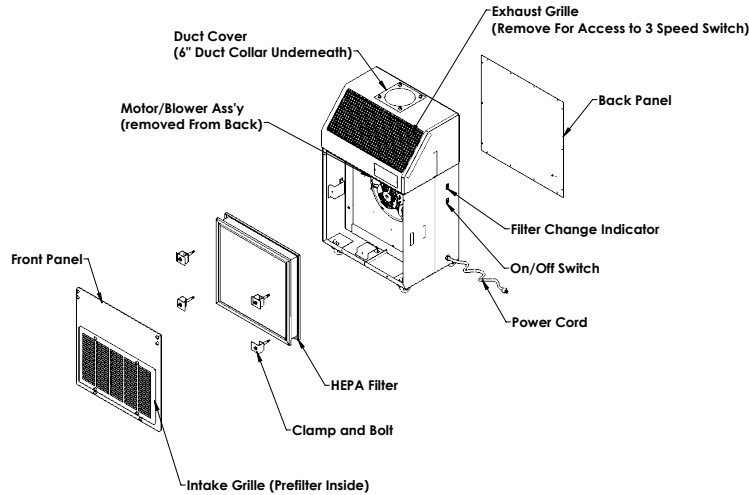

Hospi-Gard IsoClean 400 UV

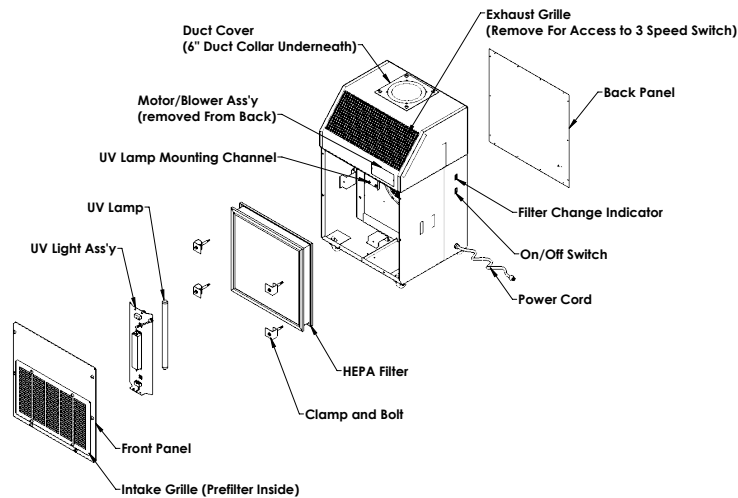

CAUTION: PROPER PROTECTIVE EQUIPMENT AND MEASURES MUST BE USED AT ALL TIMES DURING UNIT CLEANING AND MAINTENANCE. CHECK WITH YOUR SAFETY OFFICE TO ASSURE THE CLEANING SOLUTIONS, PROTECTIVE EQUIPMENT (DISPOSABLE HOSPITAL GOWN, HEPA RESPIRATOR, PROTECTIVE GLOVES) AND PROTOCOLS FOLLOWED COMPLY WITH YOUR FACILITY'S AND CDC GUIDELINES.

CAUTION: DISCONNECT THE UNIT FROM THE ELECTRICAL POWER SOURCE BEFORE ATTEMPTING SERVICE. DO NOT WORK INSIDE THE ISOCLEAN UV WITH THE UV LIGHT ON. PROPER REPLACEMENT OF UV CONTAINMENT Baffles AFTER MAINTENANCE IS MANDATORY TO MAINTAIN SAFE SHORT-TERM AND LONG-TERM UV EXPOSURE LEVELS.

Cleaning the Unit

1. Periodic Cleaning of the unit may be done with a mild disinfecting soap and water solution. A 1% or 1/100 dilution of bleach is an optional disinfectant³.
2. Exterior cabinet cleaning must be performed with the unit running. Wipe the exterior of the unit with a damp sponge or cloth, paying particular attention to the prefilter intake grille.

³ Rutala WA, APIC guideline for selection and use of disinfectants, Am J Infect Control 1996 Aug ; 24(4): 313-42.

Installation, Operation, & Maintenance Manual

Prefilter Replacement

1. The prefilter should be replaced every 60 to 90 days. Regularly replacing the prefilter will maximize the life of the HEPA filter. The IsoClean comes standard with an anti-microbial pleated prefilter.
2. Clean the unit as described in the previous section.

THE FOLLOWING STEPS MUST BE PERFORMED WITH THE UNIT (FAN) RUNNING:

3. Spray a mist of phenolic disinfectant such as “Amply “ or “Lysol” into the air intake grille.
4. Remove the four (4) screws from the face of the intake grille and pull the grille out.
5. Insert gloved hand into a red plastic, medical waste disposal bag. Grasp the top portion of the prefilter with bagged hand and gently pull outward. The airflow of the unit will offer a resistance to pulling the prefilter out.
6. Turn the bag inside out over the prefilter then seal the bag for containment.
7. Install a new prefilter and secure the grille by following step these instructions in reverse order of removal.

CAUTION: APPROPRIATE DECONTAMINATION PROCEDURES (SEE PAGE 11) MUST BE FOLLOWED PRIOR TO REMOVAL OF THE ACCESS PANELS TO REPLACE THE HEPA FILTER OR OTHER PARTS. CONTACT YOUR SAFETY OFFICE TO ASSURE IT CONFORMS TO YOUR FACILITY’S PROTOCOL.

Removal of Front and Rear Panels

1. Remove the front access panel by taking off the screw covers and removing the four (4) screws. The front panel may now be lifted off.
2. Remove the 18 screws securing the rear access panel. The rear panel may now be lifted off.

Primary Filter Replacement

The CDC recommends that in any application, HEPA filters should be maintained meticulously and should be carefully installed by adequately trained personnel wearing an appropriate respirator. A regular maintenance program should include procedures for installation, removal and disposal of filter elements and a program to monitor the HEPA filter for possible leakage and for filter loading.

The expected HEPA filter life should range from eighteen (18) months to two (2) years depending on the environment and prefilter maintenance schedule. The filter indicator light will give a warning of filter loading by flickering on high speed. When the light stays on at high speed, the prefilter should first be changed. If the light stays on after prefilter replacement, the HEPA filter is recommended to be changed.

1. Remove the front access panel by following the instructions under removal of front and rear panels.
2. For IsoClean® UV units, follow the steps in the below section to remove the UV Light Assembly.
3. Remove the six (or 4 for bolts and clamps holding the HEPA filter in place.
4. In many cases, filters must be decontaminated before removal. See decontamination process for more information. Tilt the top of the filter outward and slip a plastic biohazard bag over the top of the filter, and then wrap the bag over the bottom of the filter.
5. Seal the bag for containment. **Note:** It may be necessary to use two (2) biohazard bags to fully contain the filter.
6. Remove the new HEPA filter from its container and install it in the reverse order of removal. Care must be taken when handling the filter. Do not bump or squeeze the filter as this may damage the filter and render it non-effective.

Removal of the UV Light Assembly for the IsoClean® UV

WARNING - Skin or eye damage may result from directly viewing the light produced by the lamp in this apparatus. Always disconnect power before relamping or servicing. Replace lamp with lamp TUV 15W SLV, manufactured by Philips for IsoClean® 400. Replace lamp with TUV 30W SLV, manufactured by Phillips for IsoClean® 800.

1. Remove the front access panel by following the instructions under removal of front and rear panels. Set the front access panel to the side.
2. Disconnect the three-pin connector located near the UV lamp ballast and remove the wires from the wire routing clamp.
3. Remove the five (5) screws on the left hand UV containment baffle, and then lift the baffle out of the unit and set it to the side. Repeat this for the right hand UV containment baffle. (**Note:** This is for IsoClean® 800 model only)

Installation, Operation, & Maintenance Manual

4. Remove the two (2) screws that fasten it with the top of the UV lamp assembly.
5. Remove the remaining two (2) screws that fasten the mounting bracket to the cabinet and set the mounting bracket to the side.
6. Remove the two (2) screws fastening the UV lamp assembly to the bottom of the cabinet.
7. Carefully remove the UV lamp assembly taking care not to touch the glass tube.

The expected life of the UV light tube is 9,000 hours. To remove the UV light follow the below instructions.

1. Rotate the light tube 90 degrees in either direction to enable removal (you should feel tension on the tube release). To remove the light tube, carefully pull away from the UV lamp assembly, towards the HEPA filter. Dispose of the light tube (or recycle) following local guidelines.
2. Use Clean latex gloves to ensure that the new light tube remains clean. Clean the new light tube using a cloth dampened with a 10% alcohol (or ammonia) and water solution. To replace, reverse the order of removal.

Power Cord

1. With the back panel removed, unplug the white connector on the power cord.
2. Remove nut on ground wire.
3. Remove strain relief on the side of the unit.
4. Remove the old cord and replace with the new one by following the steps above in reverse order.

On/Off Switch

1. With the back panel removed, unplug the white connector on the switch and squeeze the snap-in legs to remove switch from side of the unit.
2. Install new switch by snapping it into the cutout and then connecting it to the white connector.

Speed Control Switch

1. Remove the exhaust grille by pushing down and lifting out.
2. Remove J-box screws.
3. Remove knob.
4. Remove switch screws.
5. Unplug connecting wires and replace with the new switch by following the steps above in reverse order.

Capacitor

1. With the back panel removed, remove one screw from capacitor strap. **Note:** Make sure to provide ample time for capacitor to discharge.
2. Slide capacitor out.
3. Remove the rubber boot and disconnect wires.
4. Replace with the new capacitor by following the steps above in reverse order.

Filter Change Indicator Light

1. With the back panel removed, unplug the two (2) wires and push out the filter indicator light from the inside of the unit.
2. Replace the filter indicator light by following the step above in reverse order.

Motor Assembly Removal

1. The motor can only be removed from the front side of the unit. First ensure that the front panel, UV light assembly (for UV units), and filter are removed. Refer to the removal of front and rear panels, primary filter replacement, and removal of the UV light assembly sections.
2. Remove the screw fastening the green motor ground wire to the motor panel.
3. Remove the screw fastening the black wire clamp to the motor panel.
4. Most of the motor wires feed into a quick-connect socket. Disconnect this socket from its mating half.
5. Remove the six (6) screws fastening the motor ring to the panel and remove the motor assembly from the unit.

CAUTION: WHEN REINSTALLING THE MOTOR ENSURE THAT IT DOES NOT TOUCH OR PUNCTURE THE HEPA FILTER.

Installation, Operation, & Maintenance Manual

Relocating a Contaminated Unit

NOTE: USE PROPER PROTOCOL, GOWNING, AND PROTECTIVE MEASURES.

1. If an existing unit is to be placed into storage for an extended period of time, remove and replace the prefilter.
2. Turn the unit off and disconnect from power source.
3. Clean the exterior surfaces of the unit.
4. Unlock caster wheel locks and move unit to its new location.

Unit Decontamination

NOTE: USE PROPER PROTOCOL, GOWNING, AND PROTECTIVE MEASURES DURING UNIT DECONTAMINATION.

Should decontamination of the unit be required, it is recommend to follow basic guidelines and a modified prodedure based on Decontamination of Large Spaces located in Biosafety in Microbiological and Biomedical Laboratories, 5th Ed. from the CDC. Confirm with appropriate Biosafety and Industrial Safety Professionals that the procedures meet your facility's guidelines. Decontamination should be performed by specialists with proper training and protective equipment.

The primary methods of space decontamination are:

- [Paraformaldehyde Decontamination](#)
- [Hydrogen Peroxide Vapor](#)
- [Chlorine Dioxide Gas](#)

After decontamination process has been completed, remove the HEPA filter. The filter can now be disposed of as general waste.

Phenolic Decontamination

In facilities where the above decontamination procedures are prohibited or not feasible, the unit can be disinfected by the following procedure.

1. Remove the prefilter.
2. After the intake grille and prefilter are removed, turn the unit on, and with the unit running, spray a mist of phenolic disinfectant such as Amphyl or Lysol into the air intake opening. Approximately two (2) to five (5) ounces is adequate.
3. Remove the HEPA filter. Since the filter has not been decontaminated by the methods above, the filter should be disposed of properly.

■ Troubleshooting

Before attempting to service and repair the unit, use proper protocol and follow appropriate decontamination procedures described in the following sections:

- Cleaning the Unit
- Prefilter Replacement
- Relocating a Contaminated Unit
- Unit Decontamination

Inoperative Air Flow

1. Confirm that the power cord is plugged into the building receptacle and power is present.
2. Confirm that the unit power switch is turned "ON".
3. Confirm the speed control is not in a position that is preventing airflow. Recommended to change the position for confirmation.
4. Check switch and internal wiring per Wiring Diagram (Section 6). Replace or repair faulty component(s).
5. Check the motor and replace if necessary.
6. Check the motor capacitor and replace if necessary. Recommended to change motor capacitor with motor replacement.

Installation, Operation, & Maintenance Manual

Low Air Flow

1. Check prefilter for obstruction and remove obstruction as necessary.
2. Replace dirty prefilter media.
3. Switch the speed control to the next higher airflow setting.
4. Check power supply for proper voltage, amperage and distribution frequency.
5. Check for down-stream obstructions or erratic isolation room ventilation balance.
6. Replace HEPA filter if the air velocity remains low after checking all other causes of low air flow.

High Air Flow

1. Adjust the speed control down to the next lowest setting.
2. Verify all filters are properly in place.

Excessive Contamination

1. Replace HEPA filter.
2. Verify the HEPA filter is installed properly.

■ **Wiring Diagrams**

IsoClean® 800 Wiring Diagram

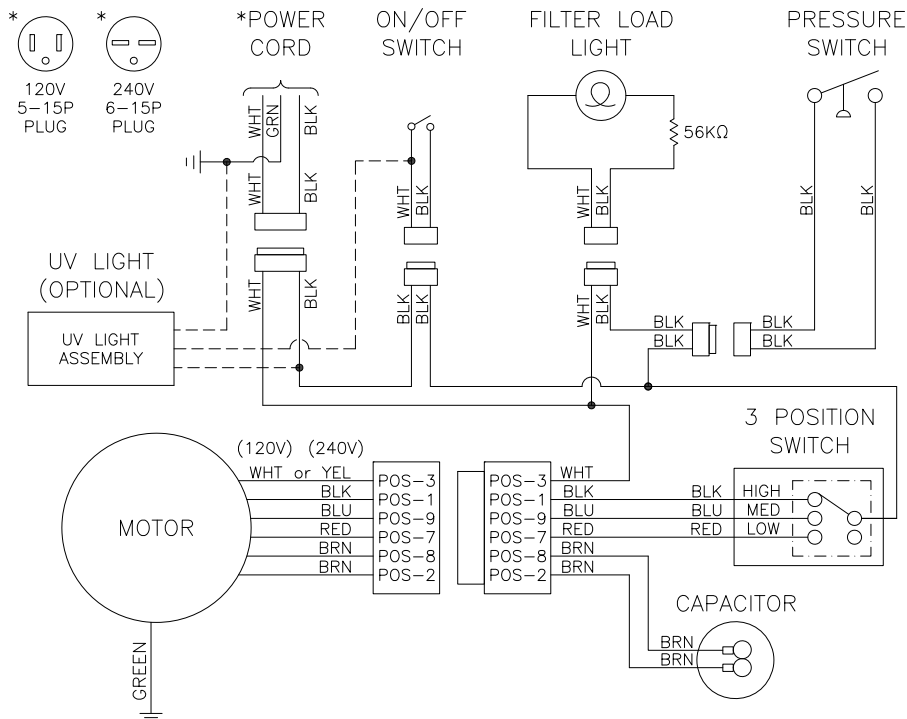

Installation, Operation, & Maintenance Manual

■ **Wiring Diagrams Cont.**

IsoClean® 400 Wiring Diagram

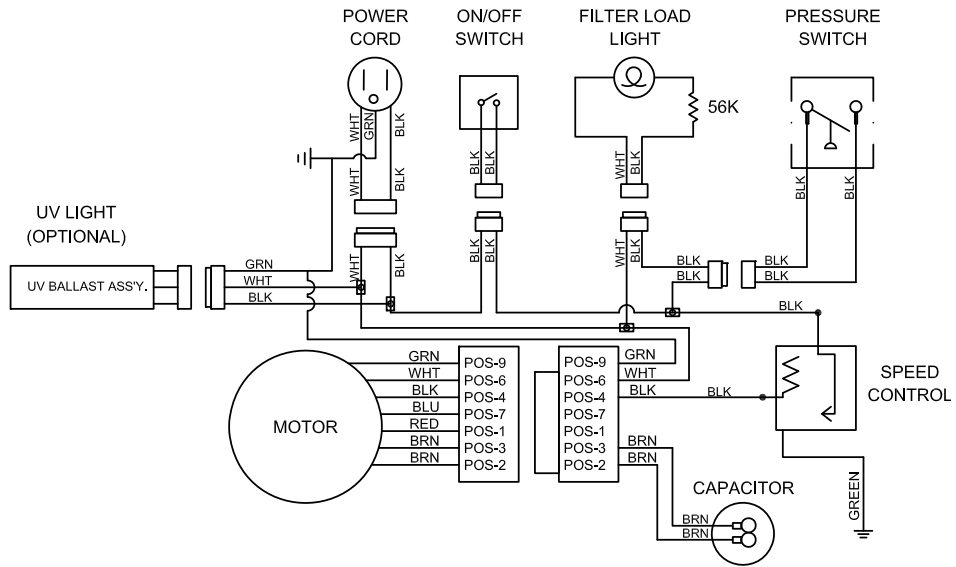

Installation, Operation, & Maintenance Manual

■ Specifications

IsoClean® 800 (10850 for 120V/10921 for 220V)

- Dimensions: 62.25 H x 23.66 W x 15.75 D (in.), 1581 H x 601 W x 400 D (mm)
- Weight: 250 lbs. (113 kg) ship weight
- Power Requirements: 6.9 A at 120V, 60 Hz, Single Phase, 3.5 A at 220V, 60 Hz, Single Phase
- Airflow: 560 CFM (951 m³/hr) on Low ±10%, 690 CFM (1172 m³/hr) on Medium ±10%, 800 CFM (1359 m³/hr) on High ±10%
- HEPA Filter Media: 99.99% at 0.3 micron minimum efficiency
- Prefilter: MERV8 multi-pleat anti-microbial pleated prefilter with frame
- Motor: 1/3 HP (0.25 kW), direct drive, three-speed, continuous duty
- Exhaust Port: 6-Inch (152.4mm) Duct Collar

IsoClean® 800 UV (10850-005 for 120V/10921-004 for 220V)

- Dimensions: 62.25 H x 23.66 W x 19.75 D (in.), 1581 H x 601 W x 502 D (mm)
- Weight: 285 lbs.(129 kg) ship weight
- Power Requirements: 8.0 A at 120V, 60 Hz, Single Phase, 4.0 A at 220V, 60 Hz, Single Phase
- Airflow: 560 CFM (951 m³/hr) on Low ±10%, 690 CFM (1172 m³/hr) on Medium ±10%, 800 CFM (1359 m³/hr) on High ±10%
- HEPA Filter Media: 99.99% at 0.3 micron minimum efficiency
- Prefilter: MERV8 multi-pleat anti-microbial pleated prefilter with frame
- Motor: 1/3 HP (0.25 kW), direct drive, three-speed, continuous duty
- Exhaust Port: 6-inch (152.4mm) Duct Collar

IsoClean® 400 (10950 for 120V/10960 for 220V)

- Dimensions: 38.25 H x 23.66 W x 15.75 D (in.), 972 H x 601 W x 400 D (mm)
- Weight: 153 lbs. (70 kg) ship weight
- Power Requirements: 2.8 A at 120V, 60 Hz, Single Phase, 1.5 A at 220V, 60 Hz, Single Phase
- Airflow: 70 CFM (118 m³/hr) at minimum ±10% and 370 CFM (628 m³/hr) on High ±10%
- HEPA Filter Media: 99.99% at 0.3 micron minimum efficiency
- Prefilter: MERV8 multi-pleat anti-microbial pleated prefilter with frame
- Motor: 1/4 HP (0.19 kW), direct drive, three-speed, continuous duty
- Exhaust Port: 6-Inch (152.4mm) Duct Collar

IsoClean® 400 UV (10950-005 for 120V/10921-004 for 220V)

- Dimensions: 38.25 H x 23.66 W x 19.75 D (in.), 972 H x 601 W x 502 D (mm)
- Weight: 173 lbs.(79 kg) ship weight
- Power Requirements: 2.9 A at 120V, 60 Hz, Single Phase, 1.6 A at 220V, 60 Hz, Single Phase
- Airflow: 70 CFM (118 m³/hr) at minimum ±10% and 370 CFM (628 m³/hr) on High ±10%
- HEPA Filter Media: 99.99% at 0.3 micron minimum efficiency
- Prefilter: MERV8 multi-pleat anti-microbial pleated prefilter with frame
- Motor: 1/4 HP (0.19 kW), direct drive, three-speed, continuous duty
- Exhaust Port: 6-inch (152.4mm) Duct Collar

Installation, Operation, & Maintenance Manual

■ Replacement Parts

IsoClean® 800

Part No.	Description	Quantity
10850	IsoClean® 800 120V	1
10921	IsoClean® 800 220V	1
S62954-WIRED	Motor, 1/3 HP, 3-Speed, 115V	1
S63093-WIRED	Motor, 1/3 HP, 3-Speed, 220V	1
S24000	Motor/Blower Assembly, 120V	1
S24000-002	Motor/Blower Assembly, 220V	1
63252	Air Inlet Ring	1
63270	Blower Wheel	1
63775	3-Speed Switch	1
63779-002	Switch Knob	1
23888	Power Cord - 120V	1
23888-002	Power Cord - 220V	1
140204-002	Motor Capacitor 15 mfd, 120V	1
60078	Motor Capacitor 5 mfd, 220V	1
63027	Air Pressure Switch	1
61400	Filter Indicator Light	1
63352	Prefilter	1
S69391-001	HEPA Filter	1
S69391-002	ULPA Filter	1
62973	Caster	2
62974	Caster with Brake	2
257738-001	6-inch Duct Collar	1
257633-001	Exhaust Cover Plate for IsoClean	1
11055	8-inch Collar with Flange for 100%	1
267745-001	Intake Grille	1
37453	Exhaust Grille	1
61528	Minihelic Gauge	1
63360	Keylock	1

IsoClean® 800 UV

Part No.	Description	Quantity
10850-005	IsoClean® 800 120V UV	1
10921-004	IsoClean® 800 220V UV	1
S26954-WIRED	Motor, 1/3 HP, 3-Speed, 115V	1
S6093-WIRED	Motor, 1/3 HP, 3-Speed, 220V	1
S24000	Motor/Blower Assembly, 120V	1
S24000-002	Motor/Blower Assembly, 220V	1
63252	Air Inlet Ring	1
63270	Blower Wheel	1
63775	3-Speed Switch	1
63779-002	Switch Knob	1
23888	Power Cord - 120V	1
23888-002	Power Cord - 220V	1
140204-002	Motor Capacitor 15 mfd, 120V	1
60078	Motor Capacitor 5 mfd, 220V	1
63027	Air Pressure Switch	1
61400	Filter Indicator Light	1
63352	Prefilter	1
S69391-001	HEPA Filter	1
S69391-002	ULPA Filter	1
62973	Caster	2
62974	Caster with Brake	2
257738-001	6-inch Duct Collar	1
257633-001	Exhaust Cover Plate for IsoClean	1
11055	8-inch Collar with Flange for 100%	1
267745-001	Intake Grille	1
37453	Exhaust Grille	1
24392-001	UV Baffle Assembly	1
60265	Germicidal Lamp	1
61528	Minihelic Gauge	1
63360	Keylock	1

Installation, Operation, & Maintenance Manual

■ **Replacement Parts**

IsoClean® 400

Part No.	Description	Quantity
10950	IsoClean® 400 120V	1
10960	IsoClean® 400 220V	1
S267793-001	Motor, 1/4 HP, 3-Speed, 115V	1
S267793-002	Motor, 1/4 HP, 3-Speed, 220V	1
S24332-015	Motor/Blower Assembly, 120V	1
S24332-016	Motor/Blower Assembly, 220V	1
63252	Air Inlet Ring	1
63270	Blower Wheel	1
271806-001	Speed Control, 120V	1
271806-002	Speed Control, 220V	1
23888	Power Cord - 120V	1
23888-002	Power Cord - 220V	1
61485	Motor Capacitor 10 mfd, 370VAC	1
63027	Air Pressure Switch	1
61400	Filter Indicator Light	1
63352	Prefilter	1
S69391-005	HEPA Filter	1
S69391-006	ULPA Filter	1
62973	Caster	2
62974	Caster with Brake	2
257738-001	6-inch Duct Collar	1
257633-001	Exhaust Cover Plate for IsoClean	1
11055	8-inch Collar with Flange for 100%	1
267745-001	Intake Grille	1
37453	Exhaust Grille	1
61528	Minihelic Gauge	1
63360	Keylock	1

IsoClean® 400 UV

Part No.	Description	Quantity
10950-005	IsoClean® 400 120V UV	1
10960-005	IsoClean® 400 220V UV	1
S267793-001	Motor, 1/4 HP, 3-Speed, 115V	1
S267793-002	Motor, 1/4 HP, 3-Speed, 220V	1
S24332-015	Motor/Blower Assembly, 120V	1
S24332-016	Motor/Blower Assembly, 220V	1
63252	Air Inlet Ring	1
63270	Blower Wheel	1
271806-001	Speed Control, 120V	1
271806-002	Speed Control, 220V	1
23888	Power Cord - 120V	1
23888-002	Power Cord - 220V	1
61485	Motor Capacitor 10 mfd, 370VAC	1
63027	Air Pressure Switch	1
61400	Filter Indicator Light	1
63352	Prefilter	1
S69391-005	HEPA Filter	1
S69391-006	ULPA Filter	1
62973	Caster	2
62974	Caster with Brake	2
257738-001	6-inch Duct Collar	1
257633-001	Exhaust Cover Plate for IsoClean	1
11055	8-inch Collar with Flange for 100%	1
267745-001	Intake Grille	1
37453	Exhaust Grille	1
60265-002	Germicidal Lamp	1
61528	Minihelic Gauge	1
63360	Keylock	1

For IsoClean 400 units purchased prior to February 2021, contact the factory for verification of correct motor, motor/blower, and capacitor parts.

Installation, Operation, & Maintenance Manual

■ **Airflow Measurement & Testing**

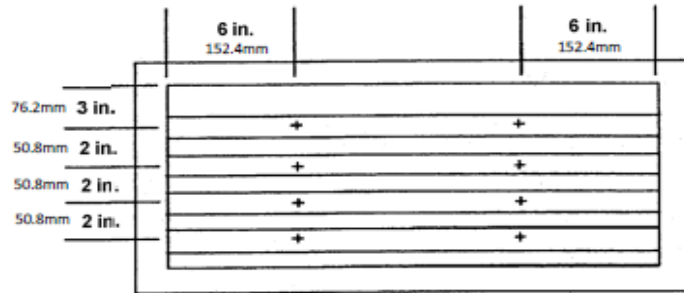

Intake Grille
8 Measurements with Velprobe or Thermoanemometer

Effective open area = 1.16 Sq. Ft.

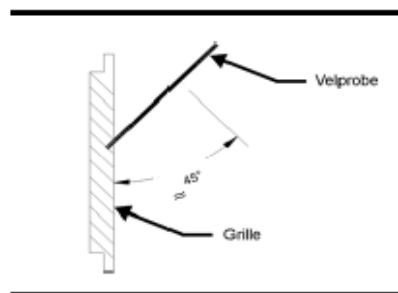

■ **Air Change Rates**

Isoclean Model	Fan Speed	Room Size (Room Air Volume) in Feet						
		10 x 10 x 8 (800 ft ³)	12 x 12 x 8 (1152 ft ³)	12 x 15 x 8 (1440 ft ³)	12 x 15 x 9 (1620 ft ³)	15 x 15 x 8 (1800 ft ³)	15 x 20 x 8 (2400 ft ³)	20 x 20 x 8 (3200 ft ³)
800	Low 560 CFM	42 ACH	29 ACH	23 ACH	20 ACH	18 ACH	14 ACH	10 ACH
800	Medium 690 CFM	51 ACH	35 ACH	28 ACH	25 ACH	23 ACH	17 ACH	12 ACH
800	High 800 CFM	60 ACH	41 ACH	33 ACH	29 ACH	26 ACH	20 ACH	15 ACH
400	Min 70 CFM	5 ACH	3 ACH	2 ACH	2 ACH	2 ACH	1 ACH	1 ACH
400	Max 370 CFM	27 ACH	19 ACH	15 ACH	13 ACH	12 ACH	9 ACH	6 ACH

Installation, Operation, & Maintenance Manual

■ Limited Warranty

a) Unless otherwise set forth in the Sales Confirmation, Seller warrants to Buyer, for a period of twelve (12) months following the date of shipment to the Delivery Location (the "Warranty Period"), that the Goods will be free from defects in material and workmanship. Notwithstanding the foregoing, the Warranty Period for consumable Goods shall in no event exceed recommended replacement intervals set forth in the Instructions (hereinafter defined). If, prior to the expiration of the Warranty Period, Buyer informs Seller in writing of any breach of this limited warranty, then Seller may repair or replace the Goods that gave rise to such breach or, in Seller's sole and exclusive discretion, refund the amounts that Buyer paid for such Goods.

The foregoing limited warranties do not apply to (i) any defect in Goods not manufactured by Seller; and (ii) any Goods manufactured according to Buyer's specifications.

(b) Buyer shall bear the costs of access, de-installation, re-installation and transportation of the Goods to Seller and back to Buyer. Any repair or replacement pursuant to this limited warranty shall not extend the Warranty Period. Seller does not warrant the Goods, or any repaired or replacement parts, against normal wear and tear. This limited warranty and remedy are expressly conditioned upon: (i) Buyer's payment of the purchase price in full, (ii) Buyer giving written notice of the defect, reasonably described, to Seller within ten (10) days of the time when Buyer discovers or ought to have discovered the defect, (iii) the storage, installation, operation, use, and maintenance of the Goods in compliance with the published specifications and instructions provided by Seller or its suppliers or subcontractors (the "Instructions"), (iv) the existence of proper records of Buyer's operation and maintenance of the Goods during the Warranty Period, (v) Buyer providing Seller with a reasonable opportunity to examine the Goods and the aforementioned records, and (vi) the absence of any unauthorized modification or repair of the Goods.

(c) Before any test may be used to evaluate the Goods, Buyer shall: (i) provide Seller with reasonable written notification of such test, (ii) allow Seller to be present during such test, and (iii) receive Seller's consent to the conditions of such test, which consent will not be unreasonably withheld. If a test is performed on the Goods, and Seller has not consented to the conditions of such test, then this limited warranty shall be void.

(d) THE REMEDIES SET FORTH IN THIS SECTION ARE BUYER'S SOLE AND EXCLUSIVE REMEDIES FOR ANY FAILURE OF SELLER TO COMPLY WITH ITS OBLIGATIONS UNDER THIS AGREEMENT, INCLUDING ANY BREACH OF THE LIMITED WARRANTY SET FORTH IN THIS SECTION. Correcting any defect in the manner set forth in this Section 8 shall constitute complete fulfillment of Seller's obligations and liabilities under the Agreement following the delivery of the Goods, regardless of whether a claim is based in contract law, tort law (including negligence, strict liability or otherwise), or other legal theory.

THE LIMITED WARRANTY SET FORTH IN THIS SECTION IS EXCLUSIVE AND IN LIEU OF ALL OTHER WARRANTIES, WHETHER STATUTORY, EXPRESS, OR IMPLIED. EXCEPT AS SET FORTH IN THIS SECTION, SELLER MAKES NO EXPRESS OR IMPLIED WARRANTIES, INCLUDING, BUT NOT LIMITED TO ANY WARRANTIES OF MERCHANTABILITY, NON-INFRINGEMENT, OR FITNESS FOR A PARTICULAR PURPOSE, OR ANY WARRANTIES ARISING FROM COURSE OF DEALING OR USAGE OF TRADE. Any other oral or written statements, whether contained in general advertising or other printed material, do not constitute warranties, and Buyer agrees that it is not entering into the Agreement in reliance upon any such statements.

■ Contact Envirco

For warranties, replacement parts, technical support, or any other questions please contact Envirco at 1-800-884-0002. For tech support related issues including troubleshooting and warranty, please email techsupport@envirco.com. For customer service related issues including parts ordering, please email customerservice@envirco.com.

Installation, Operation, & Maintenance Manual

This page intentionally left blank.

Clean air solutions built for you.

MORE INFORMATION AVAILABLE AT WWW.ENVIRCO.COM

■ Industrial

Cleanroom Products

- » MAC 10[®] Original
- » MAC 10[®] IQ™
- » MAC 10[®] LEAC2™
- » MAC 10[®] LEDC™
- » MAC 10[®] RFAC™
- » Ducted Ceiling Module:
DCM & RSR
- » AC or DC Control Systems

■ Hospital & Healthcare

Hospital & Healthcare

- » IsoClean[®] 800
- » IsoClean[®] 400
- » IsoClean[®] CM

■ Laboratory & Research

- » Unidirectional Flow
Horizontal Flow Bench (LF)
- » TT Table Top Horizontal
Flow Clean Bench
- » EnviraLab Sterility Module:
ESM

■ Pharmaceutical

- » Unimodule M-2 Vertical
Unidirectional Flow
Workstation
- » METD 100% Exhausted
Vertical Flow Workstation
- » Unidirectional Downflow
Module



Copyright ©2013 Envirco. All Rights Reserved.
Form P/N#: 62987 rev 0621

Envirco USA

101 McNeill Road | Sanford, NC 27330, USA
tel: 919.775.2201 | toll free: 800.884.0002 | fax: 800.458.2379
www.envirco.com | customerservice@envirco.com or techsupport@envirco.com