

STANDARDS:

1. 304 STAINLESS STEEL
2. #4 SATIN FINISH
3. 0.75" BLADE SPACING
4. COUNTERSUNK SCREWHOLES WITH STAINLESS STEEL #6 X 1.25" SCREWS

OPTIONS:

- 316 TYPE STAINLESS STEEL
- ANTI-MICROBIAL WHITE POWDER COAT PAINT FINISH
- OTHER CUSTOM COLOR

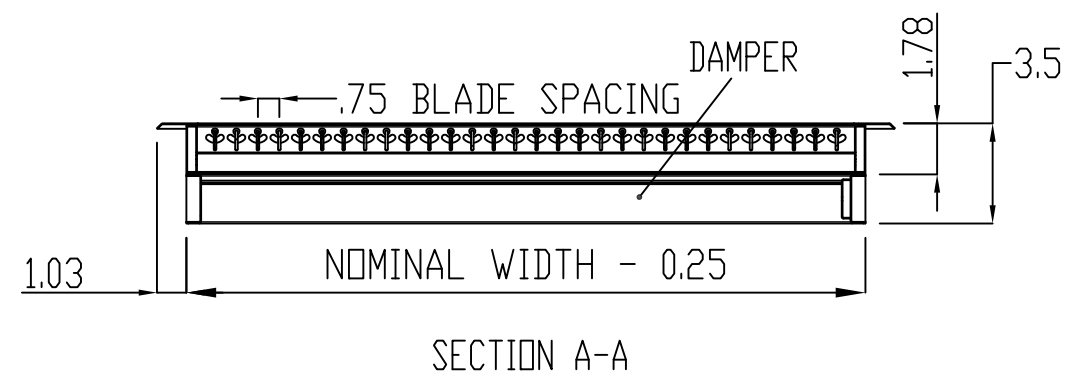
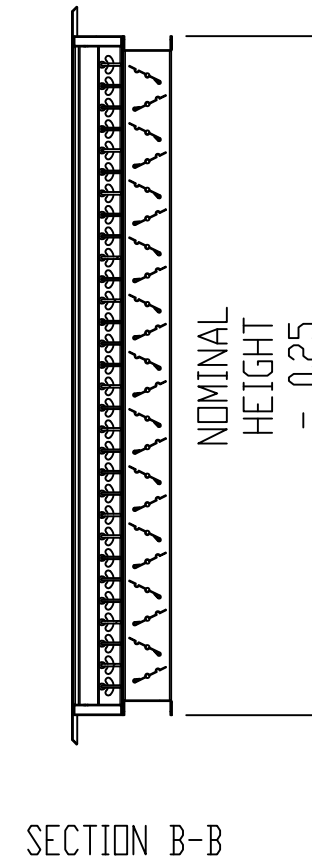
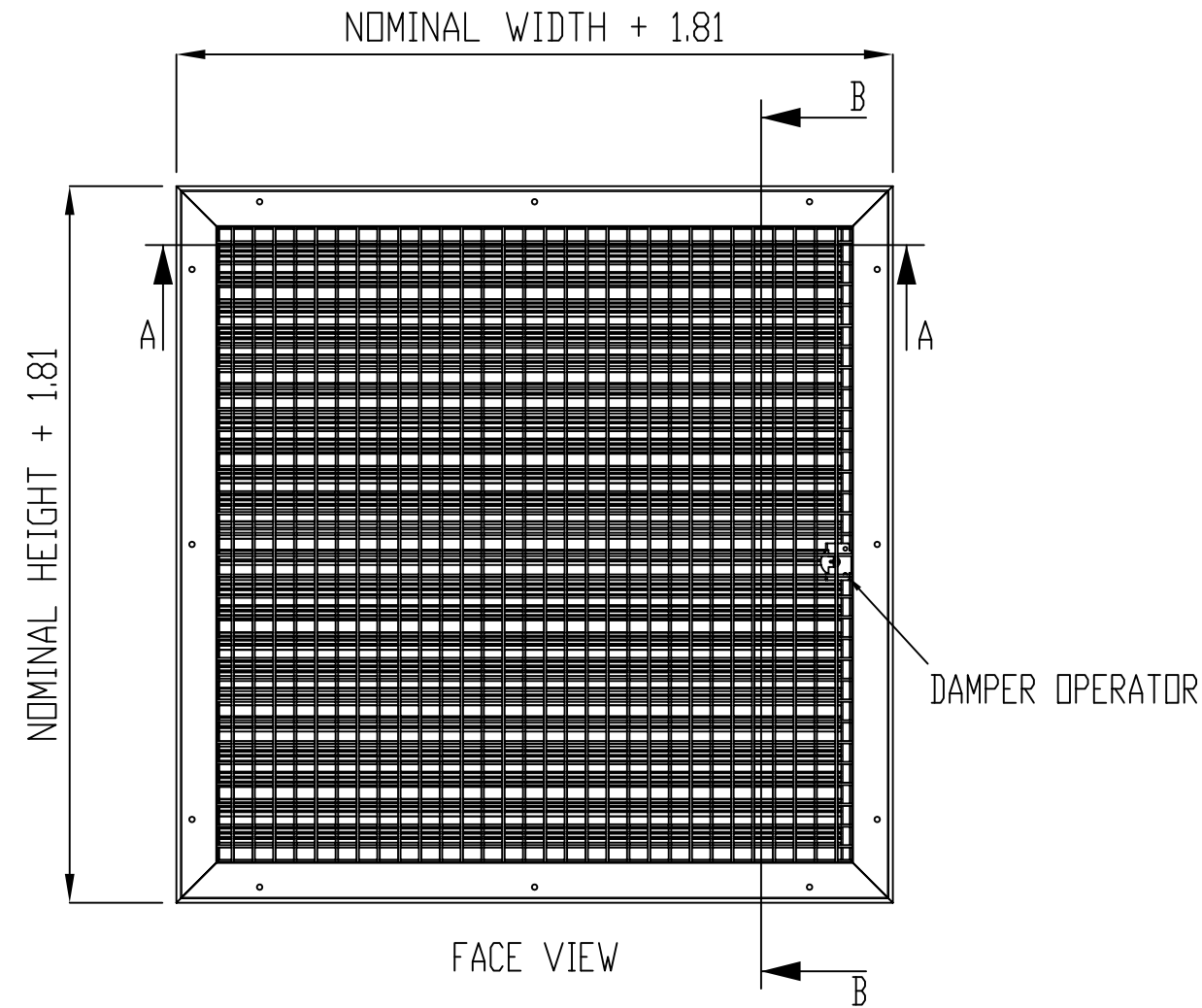

WIDTH: _____ (EVEN SIZE FROM 4" - 48")

HEIGHT: _____ (EVEN SIZE FROM 4" - 72")

SIGNATURE	_____
DATE	_____
COMPANY	_____
PROJECT	_____
P.O.	_____



101 McNeill Rd,
Sanford, NC 27330
PHONE: 919-775-2201
PHONE: 1-800-884-0002
FAX: 1-800-458-2379
www.envirco.com
email: envirco@envirco.com

CLEANROOM VENTILATION ACCESSORIES

DDSGD-V

3/4" DOUBLE DEFLECTION SUPPLY GRILLE WITH DAMPER - VERTICAL BARS

UNLESS SPECIFIED,
ALL DIMENSIONS
ARE IN INCHES.
TOLERANCE
.XX±.03 .XXX±.015
ANGULAR ±1°
UNLESS NOTED

THIS DRAWING IS THE PROPERTY
OF ENVIRCO, AND MAY NOT
BE REPRODUCED OR PUBLISHED
WITHOUT AUTHORIZATION FROM
ENVIRCO.

COPYRIGHT 2010 ENVIRCO

DRAWING NO: **DDSGD-V**

DATE: 07/27/18 DRAWN BY: CJS

REV: ~ REV DATE:

DESIGN PLAN: ECN-53969