

REV	ZONE	DESCRIPTION OF CHANGE	BY	DATE
A	-	PRODUCTION RELEASE	MAK	10/22/04
A1	-	ADDED OPTION -002 AND CENTER BAR	MAK	10/28/04
A2	-	ADDED OPTION -003 AND -004; PCN-17230	CJW	3/13/06
A3	-	ADDED OPTION -005-009	CJW	3/30/06

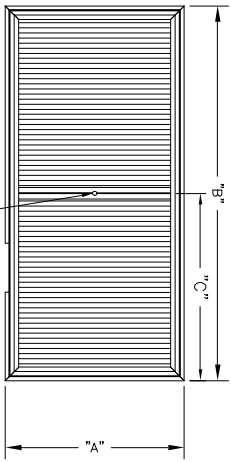

HEPA	ULPA	"A"	"B"	"C"	NOMINAL SIZE
-001	-003	22.00	46.00	N/A	2X4
-002	-004	22.00	46.00	23.00	2X4
-003	-004	22.00	22.00	N/A	2X2
-006	-007	22.00	34.00	N/A	2X3
-008	-009	22.00	40.00	N/A	2X3.5

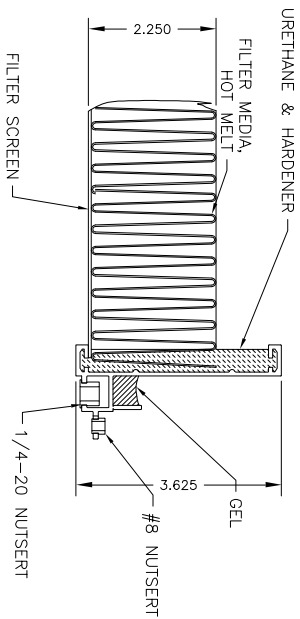
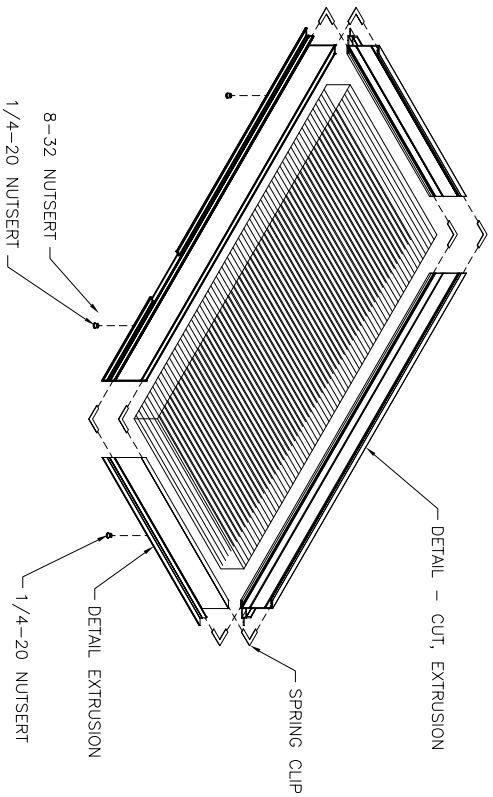
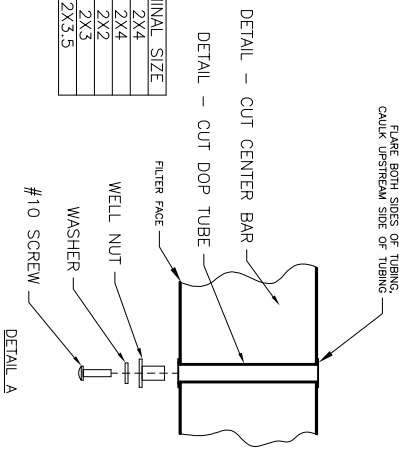

- SEQUENCE OF ASSEMBLY
1. INSERT ALL SPRING CLIPS IN THE LONG SIDE PIECES OF EXTRUSION
  2. APPLY SIKAFLEX CAULK TO ALL 45 ANGLES BEFORE SQUARING THE HOUSING.
  3. APPLY THE EXTRA CAULK FROM THE EXTERIOR OF THE HOUSING.
  4. POUR FIRST LONG SIDE OF FILTER AND INSTALL SCREEN AND FILTER PACK.
  5. INSTALL SECOND LONG SIDE AND POT FILTER
  6. COMPLETE THE POURING PROCESS
  7. PRIOR TO POURING THE GEL INTO TO THE GEL TRACK, SEAL THE CORNERS FOR THE TRACK WITH SIKAFLEX.

NOTES: UNLESS OTHERWISE SPECIFIED

THIS DRAWING IS A PROPERTY OF ENVIRCO CORPORATION AND MAY NOT BE USED, REPRODUCED, PUBLISHED, OR DISCLOSED TO OTHERS WITHOUT EXPRESS AUTHORIZATION BY ENVIRCO CORP.

TOLERANCES UNLESS OTHERWISE SPECIFIED
X = ±0.1
.XX = ±0.03
.XXX = ±0.015
ANGLE = ±1/2°
FRACTION = ±3/16"
DO NOT SCALE DRAWING

**ENVIRCO CORPORATION**  
Copyright 1993 Enviro corporation  
 5601 BALLOON FESTA PKWY NE  
 ALBUQUERQUE, NM 87113  
 PHONE:(505) 345-3561  
 FAX:(505) 345-8875

**ASSEMBLY - GEL SEAL FILTER**  
 RSR EXTRUDED

DRAWN BY	MAK	DRAWING NUMBER	69563-XXX	REV.	A3
CHECKED BY		SCALE NTS		SHEET	1 OF 1
APPROVED BY				SIZE	C